



## BEFORE USE

If you are using the C Channel method for attaching to your vehicle, we recommend that you paint some seam sealant (ie: Fabsil liquid) onto the white C channel beading strip to protect against leaks. (see 'WHEN IT RAINS' section below).

## Rainfly First Pitching

1. Ensure that the ground you plan to pitch on is flat and even. Assemble aluminium poles and lay them on the ground.
2. Attach rainfly to the vehicle via the C channel, J rail (gutter), over the top straps, velcro straps or suction clamps and spread the awning out to the side of the vehicle (Fig 1).
3. Insert the three long aluminium poles through the grey coloured pole sleeves on the Pod tent (Fig 2).
4. When all the poles are through to the other side, locate the pole ends on one side into the metal pins (Fig 3). On the opposite side, gather the poles together and push them back into the pole sleeves so that they bend into an arch. Feed the pole sleeve fabric along the pole length as they bend and make taut. Locate pole ends into the metal pins on the opposite side. Tighten the adjustable straps.
5. Allow the Pod tent to form a half dome shape. Pull the Pod tent section away from the vehicle until the sun canopy is taut. Ensure that the fabric is even and the front entrance of the Pod tent is straight and parallel to the vehicle. The curved pole nearest to the vehicle **MUST** be vertically straight to ensure the correct tensioning across the whole Pod tent once fully pegged out.
6. Start pegging out the rainfly starting below the circular window and working around to the sides. Make sure that the fabric tension is even but not too tight. You may have to go around twice to adjust the placement of the tent pegs to make the fabric taut. Peg out the two side panels to provide more stability to the Pod tent (Fig 10).
7. Insert the two telescopic poles vertically into the eyelets located on the sun canopy edges. Next insert the horizontal adjustable cross pole and extend by opening the black lever and pulling out the 16mm pole from inside the 19mm pole. This will allow the pole to lengthen and make the canopy taut (Fig 4). Close the black lever once the fabric is straight. Raise the telescopic poles until an apex is formed in the sun canopy which allows the rain to run off.
8. There are two curtain shades that can be attached to the inside of the Pod tent. Attach by pushing the buckles through the plastic O rings. If you are camping in harsh sunlight we recommend that these be attached outside to protect the PVC window from the damaging UV rays. Using the hooks, attach to the webbing straps on the pole sleeves.
9. To fold the Pod tent back to a simple sun canopy, firstly peg out the two pre-attached guy lines on the pole sleeve so they run away from the vehicle. Gather up and roll the fabric against that pole sleeve. Clip against pole sleeve using the external buckle straps through the internal long elastic O ring straps. Repeat for each section until all the curved poles are gathered together. Make sure to use plenty of guy lines.

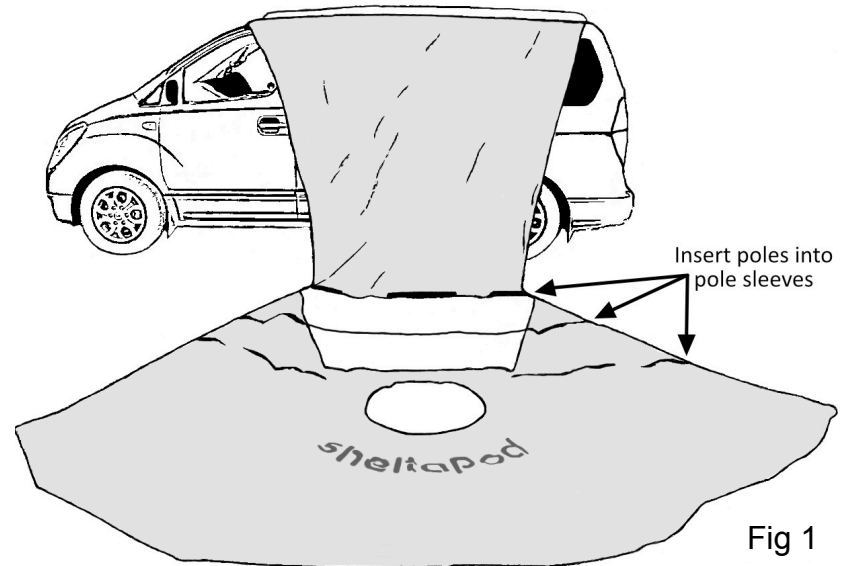

## IMPORTANT

**Immediately attach guy lines onto the two vertical pole pins and above the fabric (Fig 4) to stop it from dislodging if there is a sudden gust of wind. If this happens the pole may fall against your vehicle and scratch it. Always have a guy line attached to each vertical pole pin during use.**

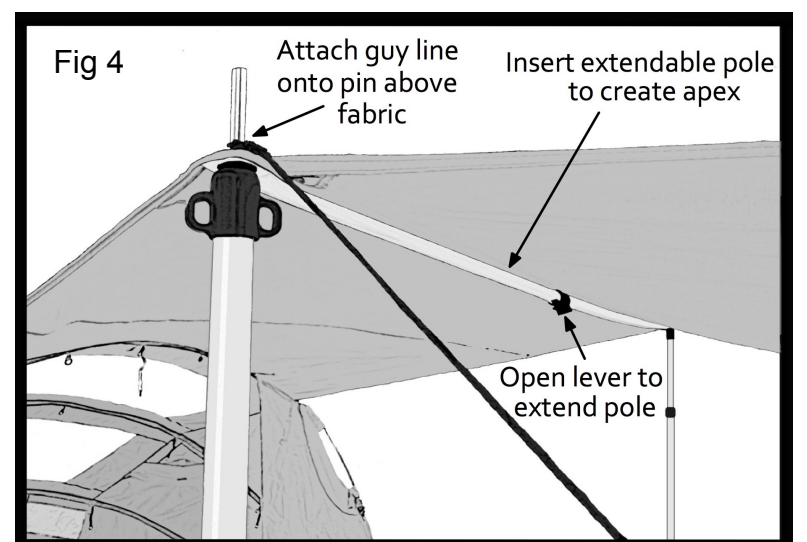
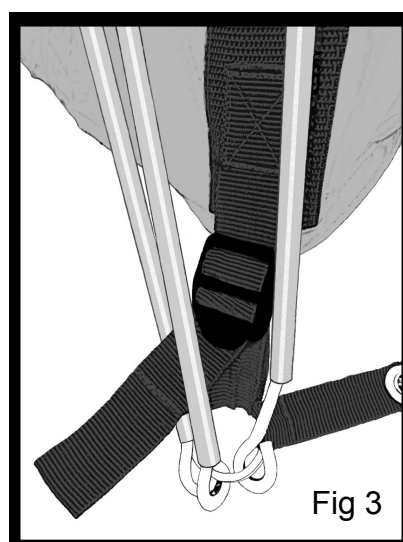
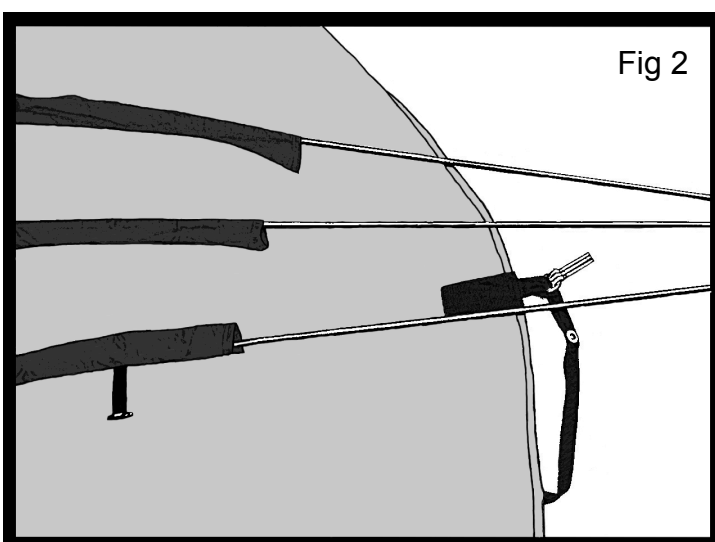

## Inner Tent Attachment

1. Lay the inner tent out on the ground inside the rainfly making sure that the zip doors are to the front entrance.
2. Peg out the front corners of the integrated ground sheet making sure they are an even distance from the sides of the rainfly (Fig 5 - Nos 1 & 2). Pull the extended anchor straps from under the rainfly and peg into the ground (Nos 3 & 4). Tighten the anchor strap to tension the groundsheet. Then do the same with the remaining corners (Nos 5 & 6). **WARNING - DO NOT PULL TOO HARD OR YOU MAY RIP THE GROUNDSHEET. LOOSEN THE WEBBING IN THE BUCKLE FIRST BEFORE PEGGING DOWN.**
3. Inside the rainfly, clip the inner tent onto the three pole sleeves by pushing the buckles through the plastic O rings.
4. To store your gear when not using the inner tent, we provide a separate front panel with access zip that can be clipped onto the front entrance in the same way as the inner tent.

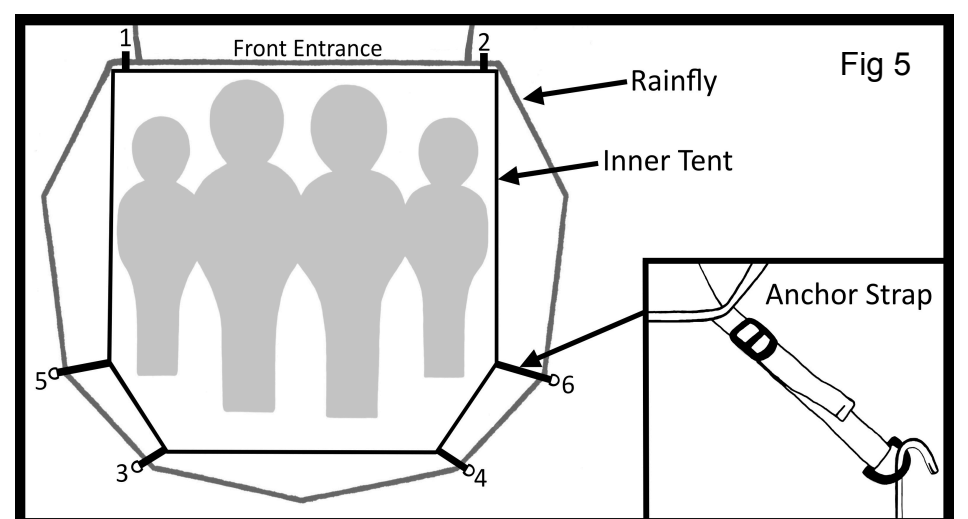

**There are two mesh panels with curtains in the inner tent. If you need more ventilation, gather up the rainfly section with the circle window and clip it back against the pole sleeve. This also provides shelter if camping in an area with lots of insects but do remember to lower the rainfly if it rains.**

**GUY LINE POSITIONS DURING STANDARD USE**

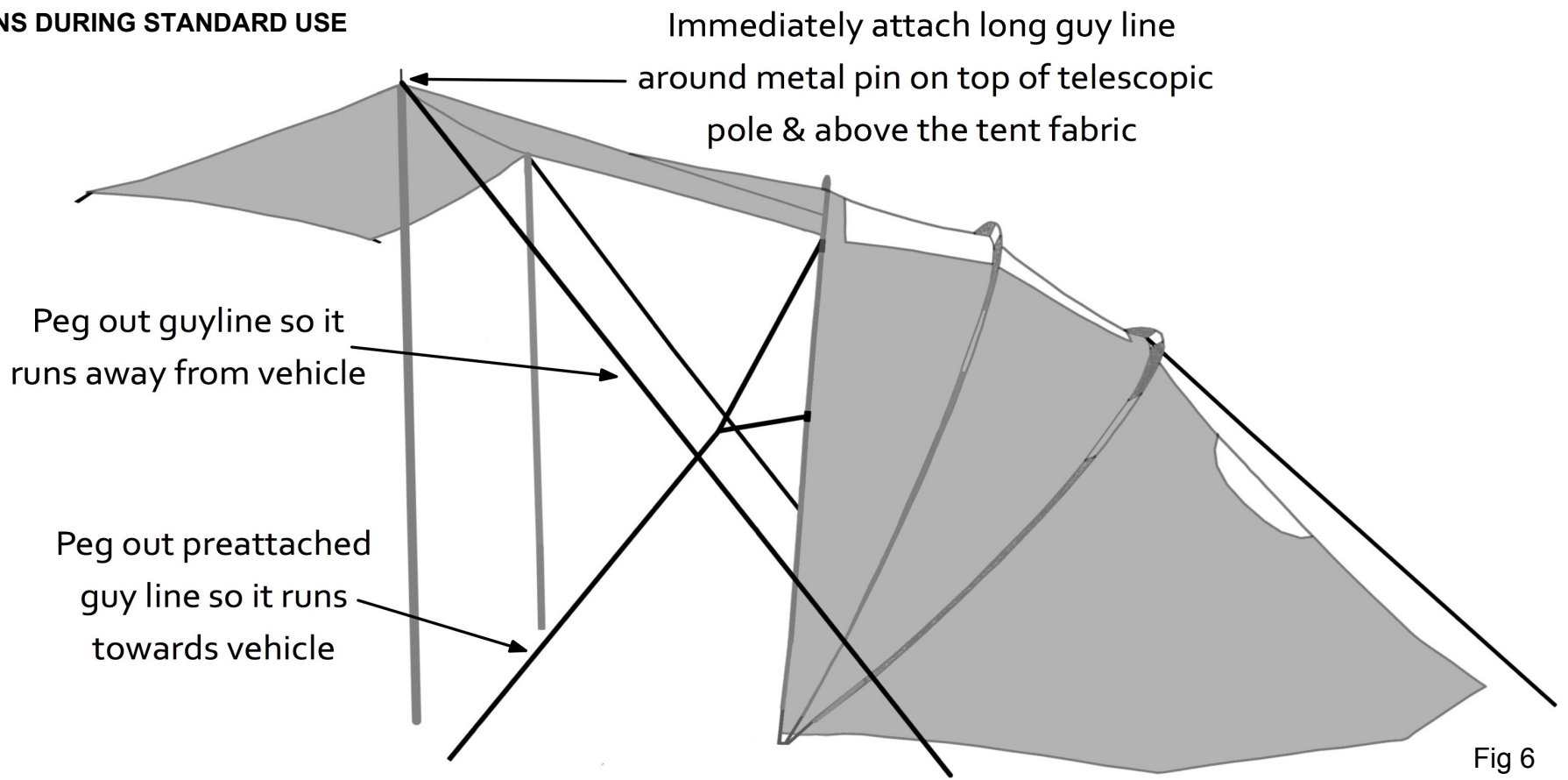

Fig 6

**DRIVE AWAY IN SHELTERED LOCATION - PLEASE FOLLOW THE BELOW STEP BY STEP PROCEDURE**  
 Insert the Front Panel to protect your gear from the weather and prying eyes. SEE BELOW ADVICE FOR WINDY LOCATIONS

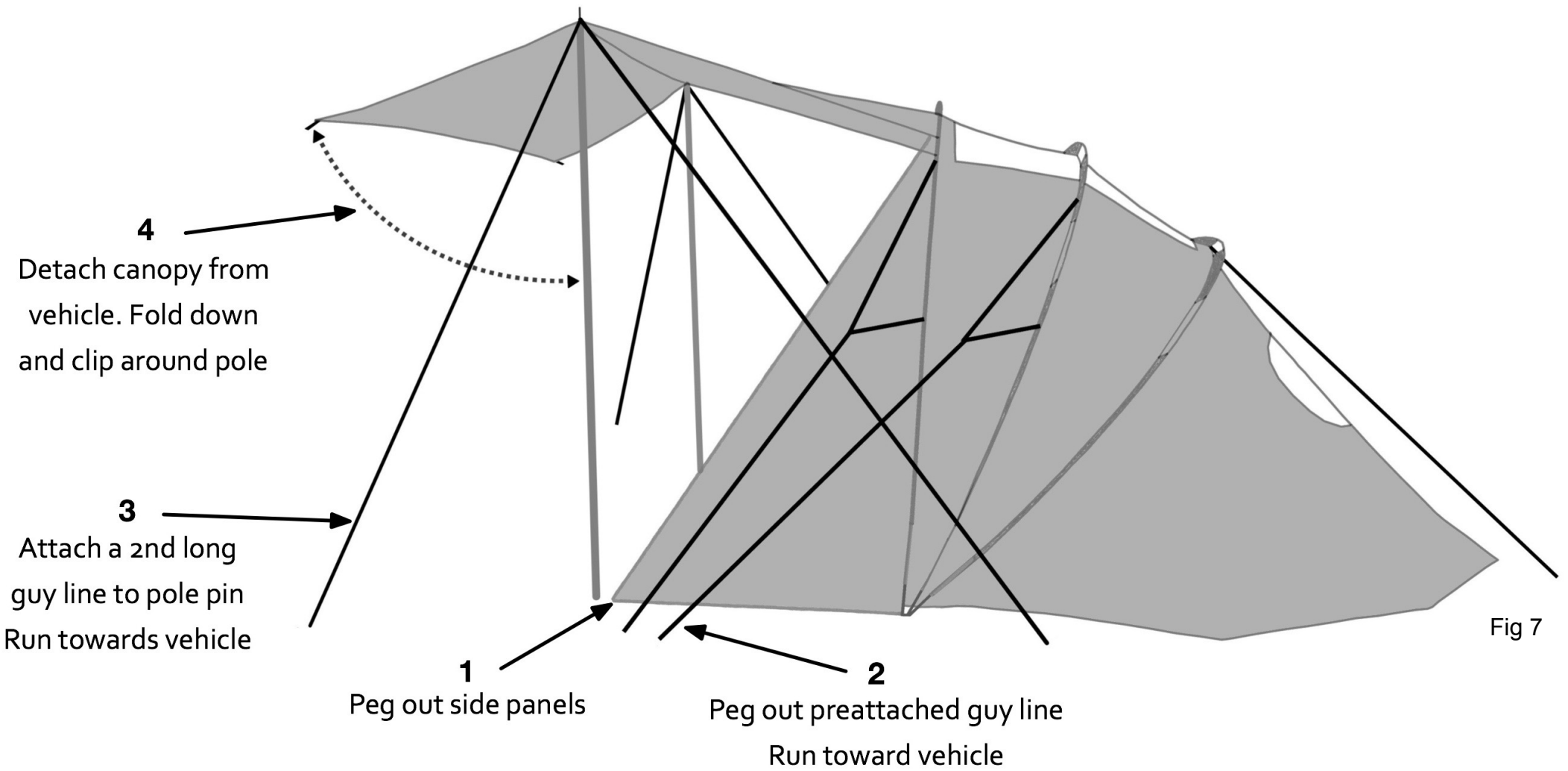

Fig 7

**ATTACHING THE PRIVACY PANEL - Fig 8**

- A. Slip eyelet in webbing strap onto the metal pole pin on top of telescopic pole.
- B. Attach plastic hook onto webbing strap on the middle pole sleeve.
- C. Wrap velcro straps around the telescopic pole.
- D. Peg the panel into the ground using tent pegs included.

– Return to A and adjust webbing strap until the panel is taut.

– There should be two privacy panels in each sheltaPod bag.

**ALSO IN THE BAG IS A SEPARATE GROUND SHEET WHICH IS FOR USE WHEN USING JUST THE RAINFLY RATHER THAN THE INNER TENT**

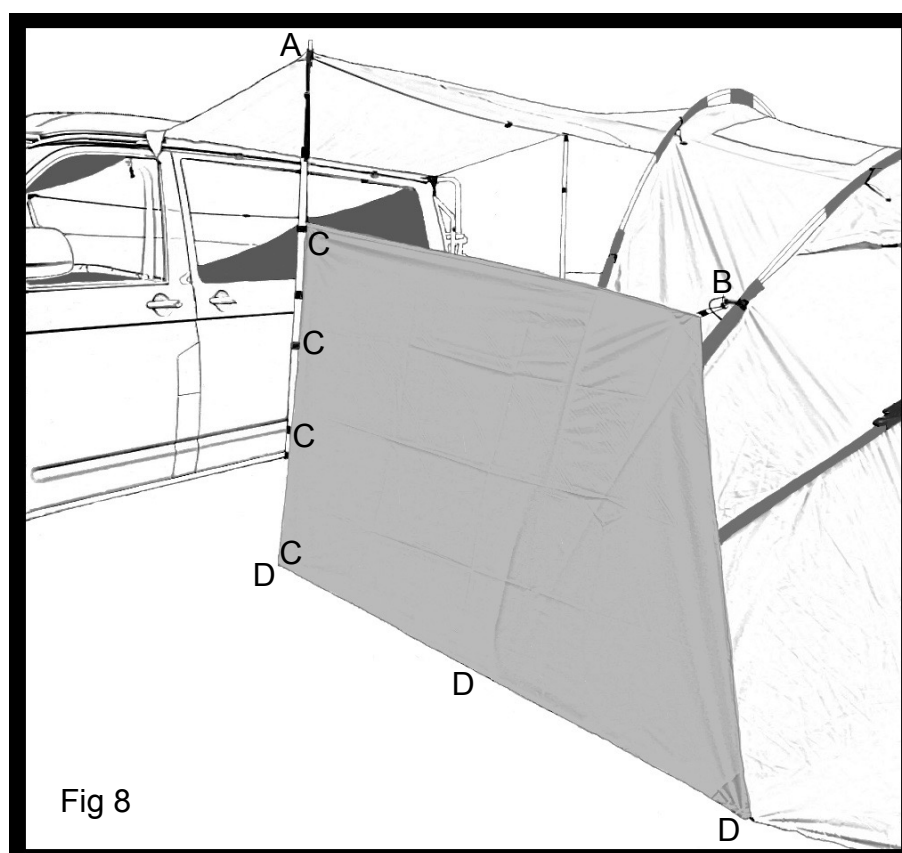

Fig 8

**SCAN QR CODE TO WATCH VIDEO ON THE SHELTAPOD DRIVE AWAY PROCEDURE OR GO TO [vimeo.com/233314020](https://vimeo.com/233314020)**



## WHEN IT RAINS

Peg out the two side panels that are attached to the Pod tent (Fig 10). This helps to direct the rainwater away from the area underneath the canopy. To stop the water from pooling around the vehicle attachment edge, lower one of the vertical poles in the canopy to let the water run off (Fig 9). This will also reduce the chance of leaks above the vehicle doorway. This is more likely to happen if you are using the C channel attachment method.

(see 'BEFORE USE' section above). Make sure to tighten the guy line attached to the vertical pole pin so that it remains taut.

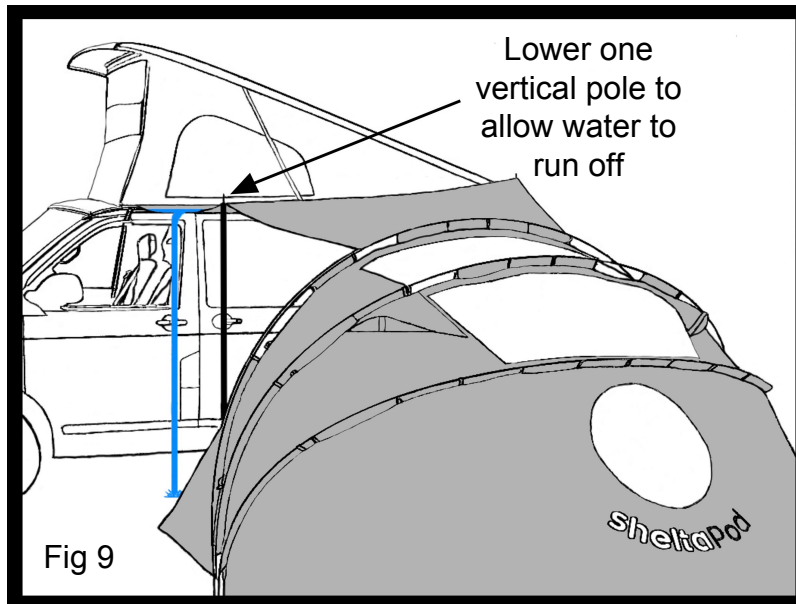

SCAN QR CODE TO WATCH VIDEO ON HOW TO SET-UP SHELTAPOD OR GO TO [vimeo.com/292518159](https://vimeo.com/292518159)



## WHEN IT GETS WINDY

The sun canopy can act like a giant sail and flap around. This puts tension on the Pod tent and the area where it attaches to the canopy. If it gets windy, we recommend that you secure the Pod tent with extra guy lines. Peg the guy lines attached to poles sleeve 1 & 2 so that they run towards the vehicle (Fig 10).

Peg the guy lines on pole sleeve 3 in the opposite direction (Fig 11). Also ensure that the side windbreaker panels are pegged out to provide extra vertical support for the Pod tent. Only detach the sun canopy from the vehicle AFTER you have followed these steps. Remove the vertical and horizontal poles, gather up the material and clip canopy above the Pod tent doorway (Fig 10). Alternatively you can peg the sun canopy into the ground for more stability (Fig 11).

If the weather forecast is for strong winds, especially overnight, we advise that you follow the above procedure as a precautionary measure. However if the winds become too strong we recommend you take the awning down and retreat into the vehicle.

**WARNING - DO NOT LEAVE THE SUN CANOPY ATTACHED TO THE VEHICLE IN WINDY WEATHER. IT WILL PUT TOO MUCH STRESS ON THE MATERIAL AND MAY RIP.**

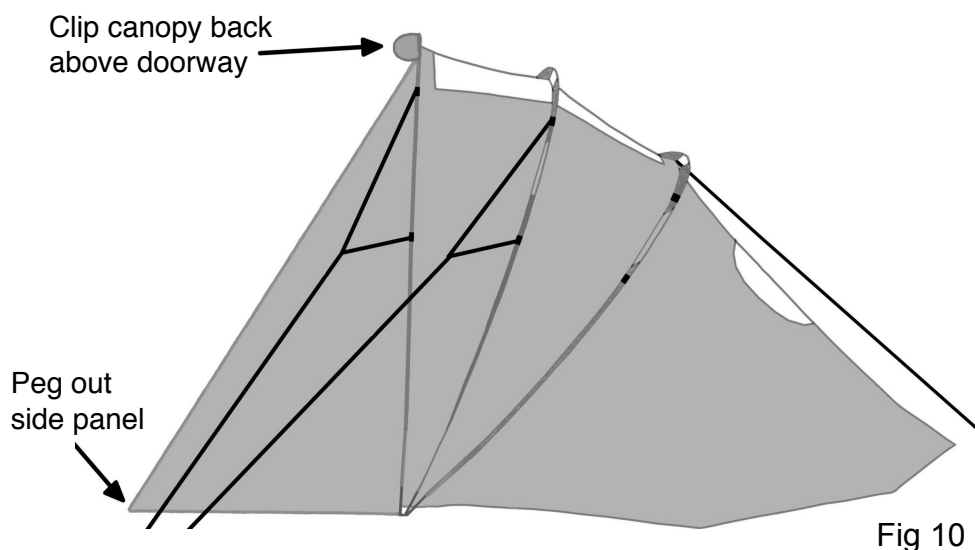

Fig 10

Alternatively you can peg the sun canopy into the ground for more stability

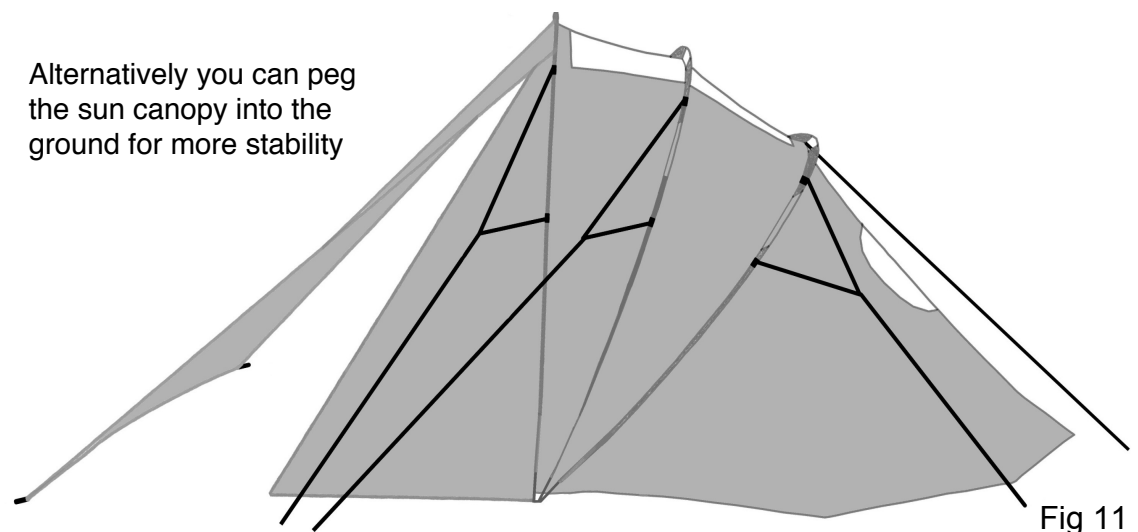

Fig 11

**Get the most out of your camping trip by having a trial run, putting up and taking down the awning in order to know it before you use it for the first time.**

## Condensation should not be confused with leakage

Under certain weather conditions, condensation can occur on the inside surfaces of the rainfly. To help prevent this you must increase the ventilation. The condensation will also evaporate once the Pod tent is heated up by the sun. The rainfly is made of waterproof material. To prevent water from seeping through the rainfly avoid touching the inside surface during rainy weather conditions.

If there are any water leaks in the rainfly or gaps in the waterproofing tape, please contact us and we will send you some free seam sealant liquid and tape.

## Taking down your awning

Clean the inside groundsheet using dustpan and brush. Remove the inner tent pegs and unclip from the pole sleeves. If necessary, clean the outer groundsheet with a sponge and water. Allow it to dry before packing it away. Remove all poles from the sun canopy. Remove all tent pegs from the Pod and allow the three poles in the pole sleeves of the Pod to lay flat on the ground. Detach the sun canopy from the campervan. Remove the poles from the metal pins and then push the poles out of the pole sleeves making sure not to catch on the material and potentially damaging it. Fold away the poles. When packing away the awning, it must be completely dry to avoid mildew/rotting. When you have folded the awning, measure it with the carry bag to make sure it is not too wide.

## Maintenance & Storage

Remove dirt from the awning with a soft sponge and pure water. Never wash the awning in a washing machine and never have it dry cleaned. Even though we have used special waterproof thread for all seams, we recommend that you use a seam sealer or a waterproof spray at regular intervals for all seams around the zips and toggles. These seams are some of the weaker points on the awning as there can be a lot of tension around them. Please note that the tape may come off after prolonged exposure to the sun. If this happens you can repair your awning by removing loose tape and use a seam sealer and waterproof spray to re-seal seams. Be aware that (UV) ultraviolet rays will damage your awning if you expose it to direct sunlight for long periods of time.

## Fire and Ventilation Precautions

Caution:

- If using gas or other combustion appliances additional ventilation is required
- Do not place hot appliances near the walls, roof or curtains
- Always observe the safety instructions for these appliances
- Never allow children to play near hot appliances
- Keep exits clear
- Make sure you know the fire precaution arrangements on the site
- Make sure ventilation openings are open all the time to avoid suffocation

**Carbon Monoxide can kill. Never use a fuel-burning appliance inside your awning/inner tent. Even a warm barbecue can be lethal**

